

Keeper Box—Operation Sheet

Body Material: 2 x 4 cut to 3" x 3" x 1 1/2"

Top Material: 3/8" pine cut to 3" x 3" x 3/8"

Finish: None, bare wood

Operations:

1. Cut wood to final dimensions
2. Drill 2 1/8" hole to within about 1/8" of bottom.
3. Create lid with 1 1/8" stopper to fit snugly into box.
or, use a wheel axel as a pivot hinge as shown in left keeper box in photograph (no stopper).
4. Use sandpaper to soften/round edges of the box.
5. Create decoration for top (heart, star, apple, mushroom, etc.)

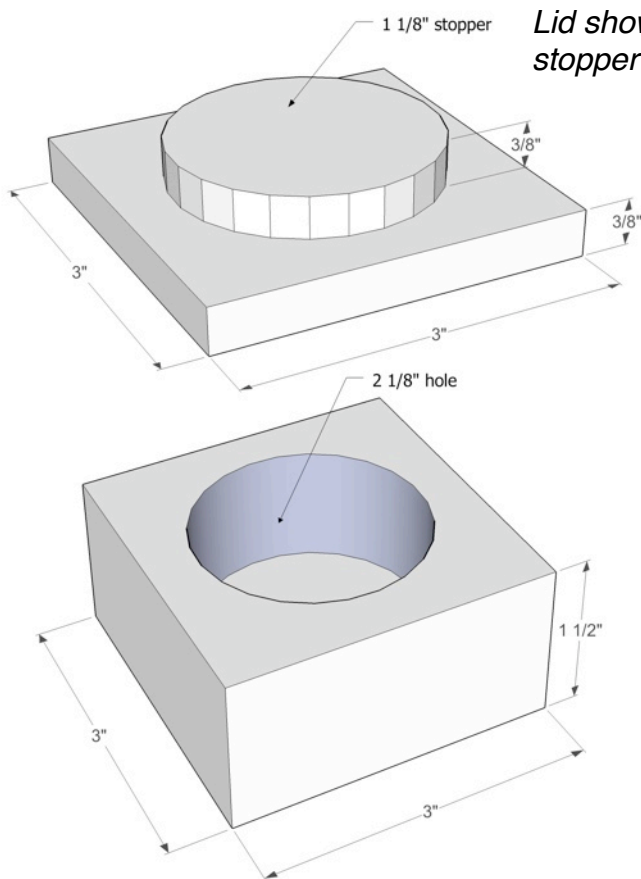

Lid shown upside down to display the stopper that fits into the box

Drawing not life-size.

